



VSM24-R

High Load (Rigid) UHV Rotation Stage

USER MANUAL

ISSUE 20260325

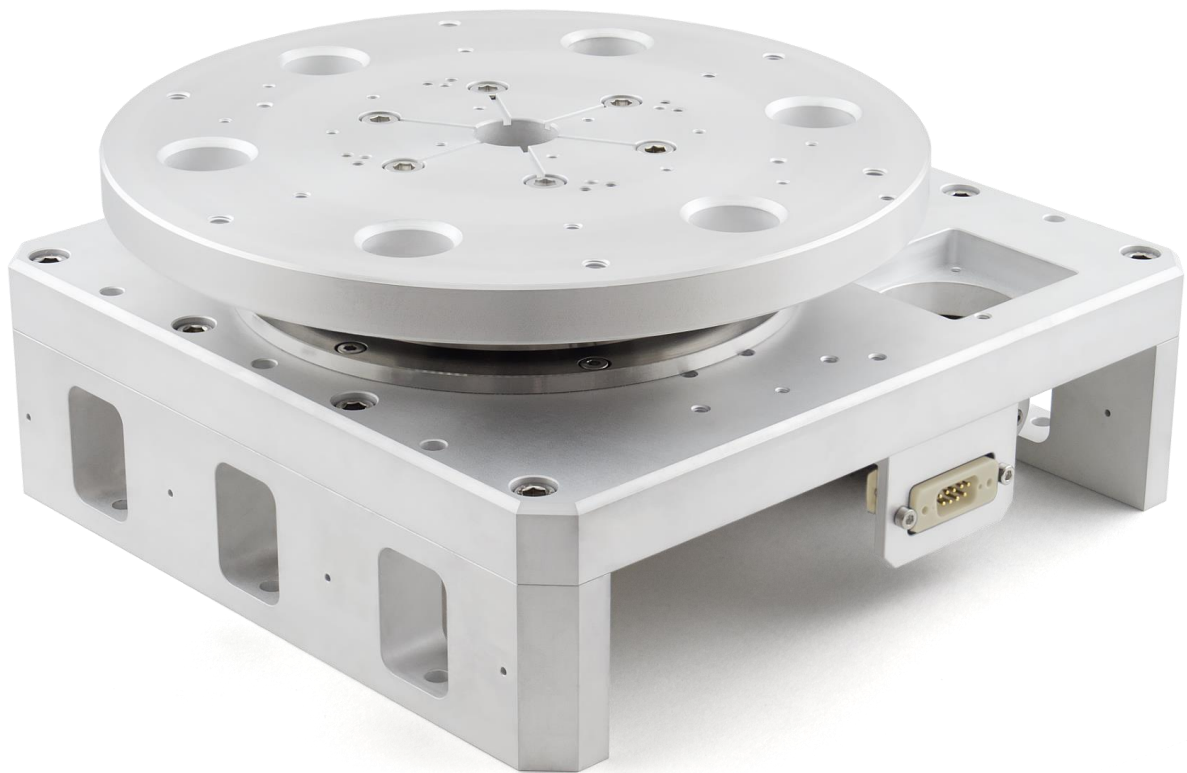

1.	Handling, Unpacking, and Shipping Restraints.....	3
2.	Lubrication.....	3
3.	Installation and Mounting.....	3
4.	Integrated D-Sub Connector.....	Error! Bookmark not defined.
5.	Operation.....	4
6.	AML Stepper Motor Drives	4
7.	Alternative Stepper Motor Drives	4
8.	Vernier Stop.....	4
9.	Bakeout	5
10.	Temperature Rise and Outgassing in Vacuum.....	5
11.	Storage and disposal	5
12.	Assistance	5

1. Handling, Unpacking, and Shipping Restraints

The assembly should not be removed from the packaging until required for installation. Always use clean gloves.

Leadscrews, worm drives, and some gearing may be lubricated. While removing the covering from these, ensure that parts nearby are covered, to avoid transfer of lubricants.

Some mechanisms are shipped with temporary screws, brackets or other hardware fitted. These are normally identified with red paint or self-adhesive red labels.

2. Lubrication

Stages are supplied lubricated with Nyetorr 6300 UHV grease unless dry lubrication was specified when ordering.

3. Installation and Mounting

The mechanism should be mounted on a flat surface through the fixing holes provided in the baseplate. Mounting on standoff spacers is acceptable and may be preferable in order to compensate for an uneven surface. Take care not to distort the baseplate. Use as many of the mounting locations possible to improve rigidity.

The VSM24-R features M6 clearance holes (figure 1) and M6 threaded holes (figure 2) for mounting.

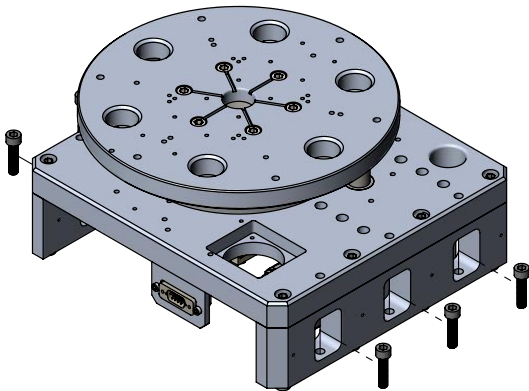

Figure 1

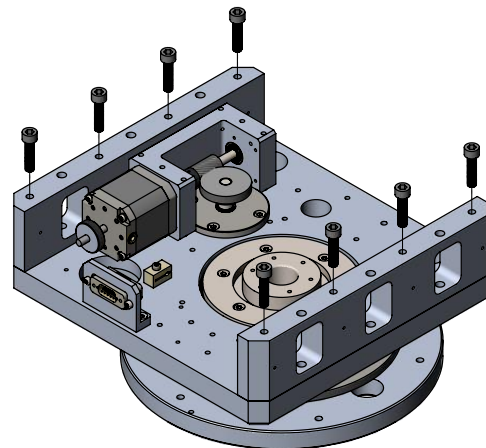

Figure 2

The mechanism does not require the mounting surface to act as a heat sink.

Do not remove or adjust any screws without understanding their function or consulting AML. Take normal vacuum precautions, avoid creating trapped volumes when mounting the mechanism and avoid obstructing the pumping holes in the end faces of the motor.

For motor connections refer to the UHV motor user manual here:

https://arunmicro.com/documentation/Manual_VCSM.pdf

The motor leads should be routed to the feedthrough in such a way that they cannot come into contact with the moving parts of the mechanism. Strain-relieve the wires if the motor moves relative to the feedthrough.

4. Operation

The mechanism should be run initially in air, so that the operation can easily be observed.

Since the moving parts for drive and guidance may not be conventionally lubricated, vibration and noise may be expected when the axes are moving. The coatings used on these parts have a much lower coefficient of friction in vacuum than in air. DLC-coatings may need baking to achieve optimum friction.

A small amount of radial movement of lead screws may be expected. The nut mounting arrangement compensates for this.

5. AML Stepper Motor Drives

AML stepper motor drives are recommended for use with AML stages. This will result in optimum mechanical and thermal management of the motor.

Acceleration and speed controls should be adjusted by experiment. Too high a speed or acceleration will result in loss of synchronism, but a low speed may excite resonances. Resonances may be controlled by changing the step division mode. Choice of a large division ratio may limit the maximum speed available. Transient resonances during acceleration may often be avoided by a faster acceleration.

6. Alternative Stepper Motor Drives

Unipolar drives are unsuitable. If alternative bipolar drives are used the range and resolution of adjustment of phase currents may be less than with AML drives. The square root of the sum of the squares of the two phase currents applied to the motor must not exceed 1A at any time. Facilities to monitor the winding temperature of the motor and remove drive current when this exceeds 190°C must be provided. Ensure that the measuring circuit connected to the thermocouple is not affected by the electromagnetic environment inside the motor. Switchmode (or 'chopper') drives must have a chopping frequency of less than 22 kHz. The phase current should be reduced when the motor is stationary for more than a few seconds. Micro-stepping is recommended for smooth operation only and not as a means of increasing resolution.

7. Vernier Stop

These stages may be driven to the vernier stops at the limits of their travel and stalled without damage.

If the position of the axis is unknown, the mechanism should be driven sufficient steps to ensure a complete traverse is taken toward the vernier stop. The position counter in the AML stepper motor drive may be recorded or preset to some convenient number when the motion is completed. All other locations may then be achieved by a single command.

If precision vernier stops are approached with a step rate of more than 500 Hz the pins will 'bounce' apart, causing an error. No damage will result. If it is necessary to slew to the stop at high speed then the carriage should subsequently be backed off a few steps before a final approach is made at slow speed to find the stop with the defined precision.

8. Bakeout

Baking at up to 150°C (200°C for option SS) is required for operation at UHV. For detailed information on bakeout, refer to the motor manual or manual of the stepper motor drive being used.



Irreversible deterioration of the winding insulation will occur at 230° and the motor will subsequently produce large amounts of gas, even at lower temperatures.

9. Temperature Rise and Outgassing in Vacuum

Refer to the motor datasheet and vacuum performance document for information on estimating gas loads. If the duty cycle of motion is relatively low this will result in the motor temperature stabilizing at about 50°C when the chamber wall is at 20°C. The average gas load from an adequately baked motor will be in the order of 1×10^{-8} mBar litre sec⁻¹ under these conditions.

10. Storage and disposal

The product must be disposed of in accordance with the relevant local regulations for the environmentally safe disposal of systems and electronic components.



In the United Kingdom (UK) and European Union (EU), waste from electrical and electronic equipment (WEEE) is subject to legislation designed to prevent the disposal of such waste and to encourage proper treatment measures to minimize the amount of waste ultimately disposed to landfill. To view AML's WEEE policy please visit: https://arunmicro.com/documentation/WEEE_procedure.pdf

11. Assistance

In the first instance, contact the distributor or supplier of the equipment. Always quote the serial number of the instrument and firmware and software versions. Provide a written description of the problem. If the problem is related to a motor or mechanism manufactured by AML, include the serial number(s) of those items. Do not return products to AML without prior approval.

Arun Microelectronics Ltd
Tel: +44 (0)1903 884141
Email: info@arunmicro.com
Website: arunmicro.com