

## UHV LOW-PROFILE LINEAR SAMPLE TRANSPORTERS, MODELS LPVxxL and LPVxxH

These mechanisms provide long travel with minimum height for loads of up to several kilograms. They have widely-spaced 'V' roller guides and are useful in simpler compound mechanisms where the torsional loads on the carriage are either small or have a small variation. Options on resolution are offered.

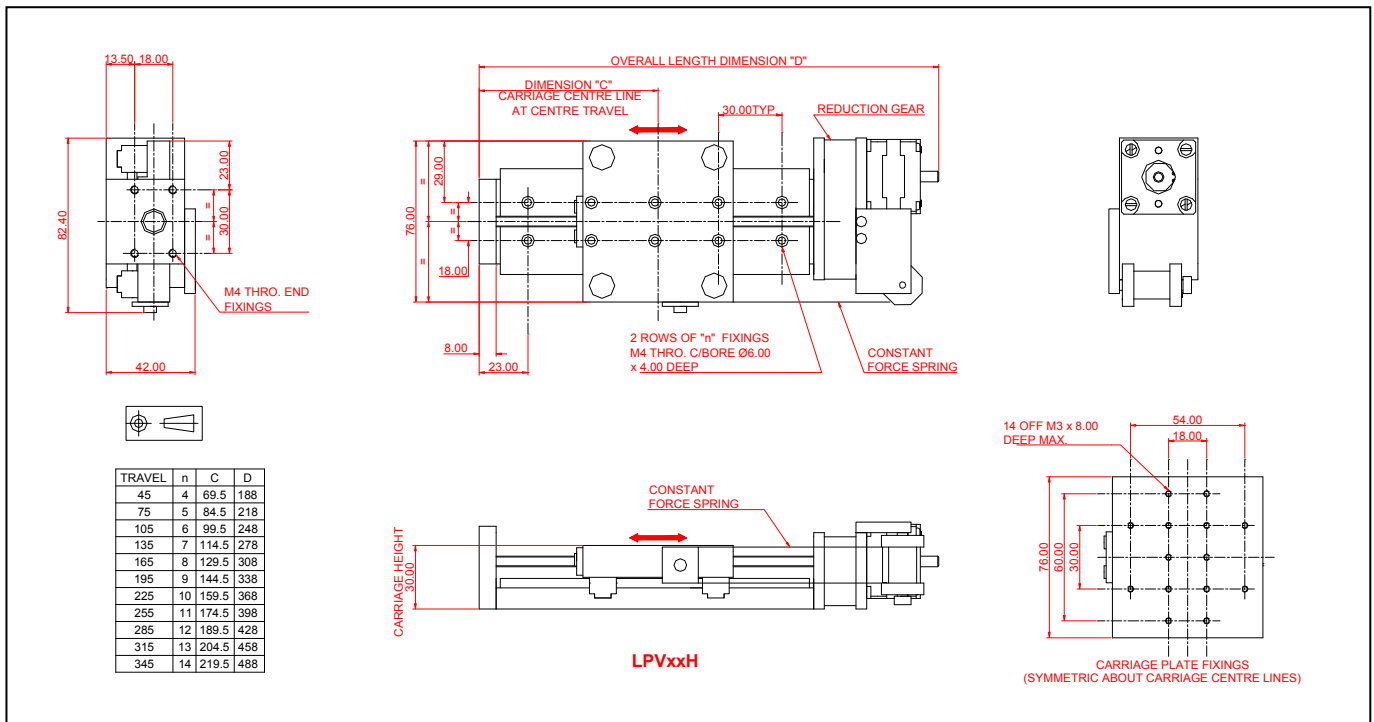

The green (first) specification figure refers to LPVxxH, shown above, and the red (second) figure to LPVxxL, shown overleaf.

- ◆ Standard travels from 45mm up to 345mm in increments of 30mm.
- ◆ Resolution 1 $\mu$ m or 4 $\mu$ m per step.
- ◆ Repeatability better than 0.2 or 1 $\mu$ m.
- ◆ Traverses up to 4 or 12mm/sec.
- ◆ Backlash negligible. See notes overleaf.
- ◆ Axial load force <10kg or <3kg at mid-speed. Normal load force (e.g. sample weight with carriage in horizontal plane) <20kg. Load moment <5Nm, about any axis through the carriage centre.
- ◆ Roll, pitch and yaw <25 $\mu$ radians, unloaded. Straightness of travel <1.3 $\mu$ m/100mm, unloaded.
- ◆ Roll, pitch and yaw compliance 33 $\mu$ radians/Nm, see notes overleaf. Normal load compliance 0.5 $\mu$ m/N on table surface 1 $\mu$ m/N on table side.
- ◆ Carriage height 30mm. Overall height 42mm.
- ◆ Directly stackable for XYZ with no additional hardware. AML CRS etc. also stack directly.
- ◆ Can be used in any orientation.
- ◆ UHV - compatible materials and construction. Aluminium alloy, non-magnetic stainless-steel, aluminium bronze. Running surfaces are dissimilar materials or suitably coated.
- ◆ May be customised (width, materials, fixings etc.) at low cost.
- ◆ Suitable for use below 1 x 10<sup>-10</sup> mBar.
- ◆ Bakeable to 200°C (limited by motor).
- ◆ Gamma radiation - hard to 1 x 10<sup>9</sup> Rad (1 x 10<sup>7</sup> Sv/Gy) with C14.1R motor.

This document and the designs depicted are the copyright of Arun Microelectronics Ltd. Specifications are subject to change, confirm before ordering. E & OE. AML acknowledges the rights of the owners of all trademarks and registered names.

# AML

*innovation in vacuum technology*

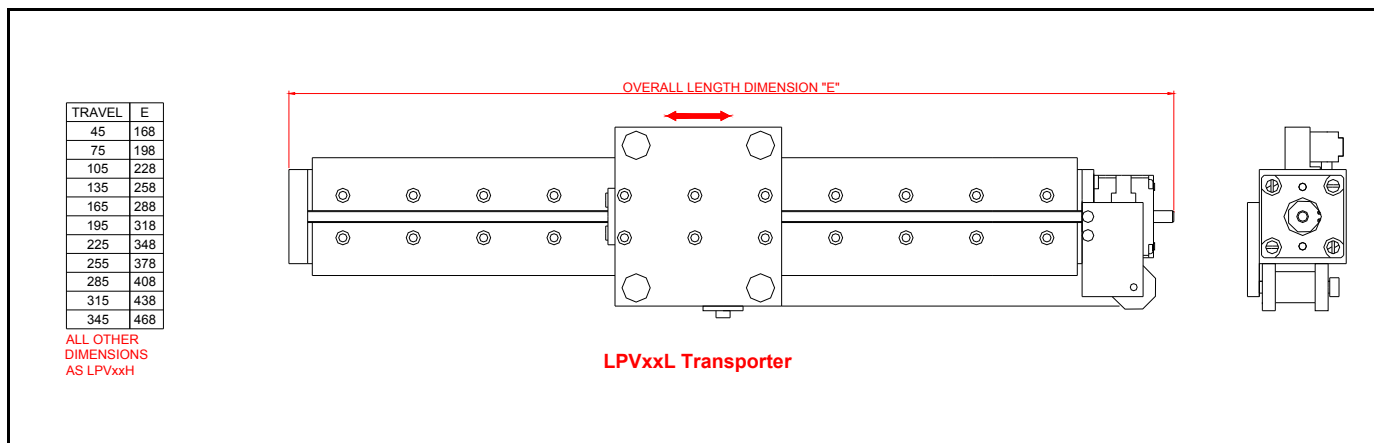

PRINCIPAL SPECIFICATIONS.	LPVxxH	LPVxxL
Resolution	1µm	4µm
Repeatability	0.2µm	1µm
Unloaded speed, lubricated @ $I_p = 1A$ , motion horizontal	>4mm sec <sup>-1</sup> ( 4 kHz )	>12mm sec <sup>-1</sup> ( 3 kHz)
Recommended loaded speed in UHV, baked, any orientation	<0.8mm sec <sup>-1</sup> ( 1kHz)	<2 mm sec <sup>-1</sup> ( 500Hz)
Axial load force @ 500Hz, $I_p = 1A$	10kg	3kg
Carriage weight	0.25kg	0.25kg
Total weight for 45mm travel Overall length	1.00kg 187.1mm	0.80kg 167.1mm
Increase in total weight per additional 30mm of travel.	0.11kg	0.11kg

**BACKLASH.** Backlash in the gearbox of LPVxxH is controlled by special gearing and is negligible. Backlash between the nut and leadscrew and axial float in the bearings is controlled by a constant-force spring and is much less than the resolution. If the transporter is used for motion with a significant vertical component (>45°), the load provided by the carriage weight is sufficient to eliminate backlash and the spring can be removed. In these cases mount with the motor at the top. Since speeds are low, acceleration forces are negligible.

**CARRIAGE COMPLIANCE.** The carriage will deflect under load moments about the principal axes by 33µradian per Nm. In most applications the load deflection will be constant and can be compensated for in the sample mount. AML can supply sample plates with 3-point, 1µ resolution adjustments for this and other purposes. For stacked XY motions in a horizontal plane the movement of the carriage and load on the upper transporter will produce a varying moment about the axis of the lower transporter. Minimise this by stacking the shorter transporter on the longer. Avoid reversals of direction of load moments by preloading.

For loads with larger moments or forces use, or for greater rigidity use an AML LPX transporter.

**VERNIER STOP.** These transporters may be driven to vernier stops at the limits of their travel and stalled without damage. See AML Application Note No.31 for a description of vernier stops.

**STACKED MECHANISMS.** For 3-axis motion mount the stage moving the load vertically on top of the others to avoid adding their weight to its load.

#### Ordering information:

e.g. **LPV75H** Low-Profile Transporter, 'V', 75mm, 1µm res.  
e.g. **LPV255L** Low-Profile Transporter, 'V', 255mm, 4µm res.  
add suffix G for Nyetorr ® 5200 lubrication (at > 1 x 10<sup>-9</sup> mBar). \*\*

\*\* consult AML for other custom features.

**C14.1** UHV Stepper Motor  
**C14.1R** UHV Stepper Motor ( Radiation-hard )

A C14.1 motor must be ordered with each transporter. The motor and mechanism will be supplied assembled together and tested.

#### Related Products:

**SMD2** Dual UHV Compatible Stepper Motor Drive.  
**MLF18xx** Feedthroughs, leads and in-vacuum connectors.

### Arun Microelectronics Ltd.

Fitzalan Road, Arundel,  
West Sussex BN18 9JP, England.  
Tel: 01903 884141 Fax: 01903 884119  
International Tel: +44 1903 884141  
www.arunmicro.com



*innovation in vacuum technology*